

Strecke

Länge breit mittel eng

Traktion hoch mittel wenig

Beschaffenheit eben mittel hügelig

Untergrund Gras Schotter Kies

Lehm Teppich Sand

Zustand trocken matsch nass staubig

Temperatur Luft Boden

Differenziale

vorne mitte hinten

Federung

vorne

soft

medium

hart

hinten

Stoßdämpferöl

vorne

Dämpfung

0.8mm 0.8mm

.....

2mm 2mm

Achermann

Karo

Stabilisator

vorne

Dicke

hinten

Übersetzungsverhältnis

1:

	A	B	C	D
6.06	35	28	24	25
6.23	32	31	26	23
6.34	33	30	25	24
6.55	26	37	30	19
6.57	35	28	23	26
6.64	31	32	26	23
6.76	32	31	25	24
6.88	33	30	24	25
7.07	30	33	26	23
7.20	31	32	25	24
7.34	32	31	24	25
7.47	33	30	23	26
7.68	30	33	25	24
7.82	31	32	24	25
7.96	32	31	23	26
8.04	28	35	26	23
8.07	37	26	19	30
8.33	30	33	24	25
8.48	31	32	23	26
8.72	28	35	25	24
9.04	30	33	23	26
9.15	26	37	26	23
9.18	35	28	19	30
9.47	28	35	24	25
9.93	26	37	25	24
10.27	28	35	23	26
10.44	33	30	19	30
10.78	26	37	24	25

A:

B:

C:

D:

Name

Rennen Datum

RACE RUNNER

MCD Racing

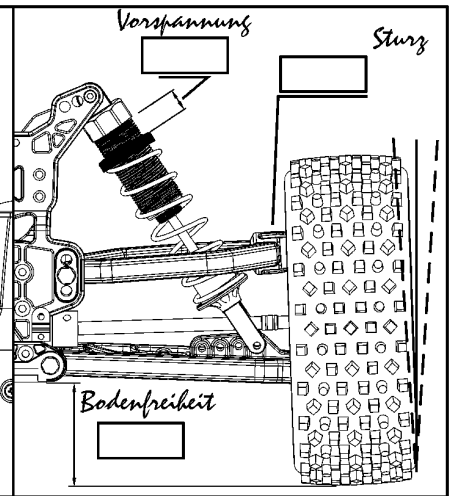
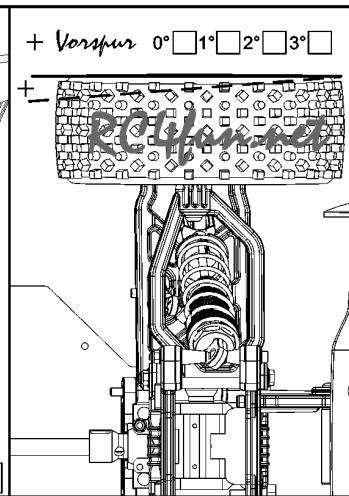
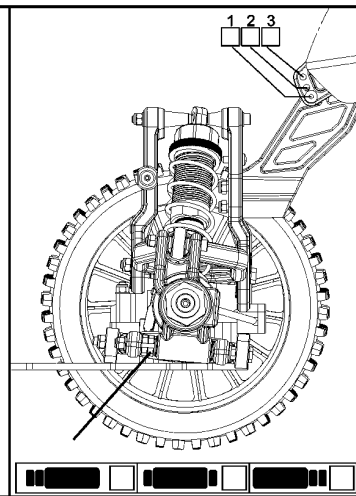
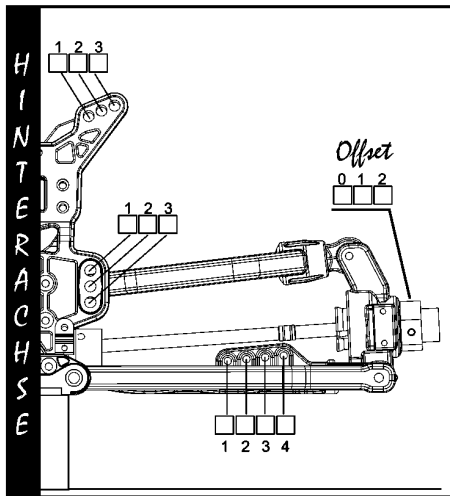
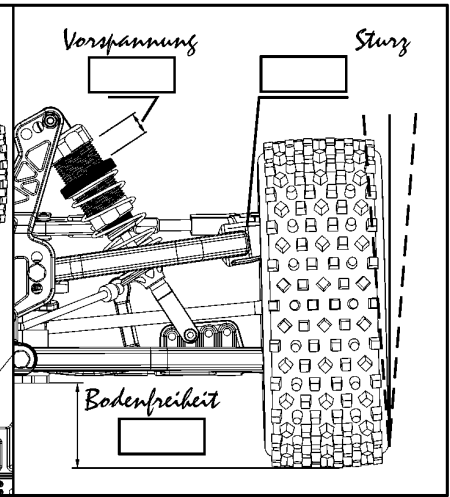
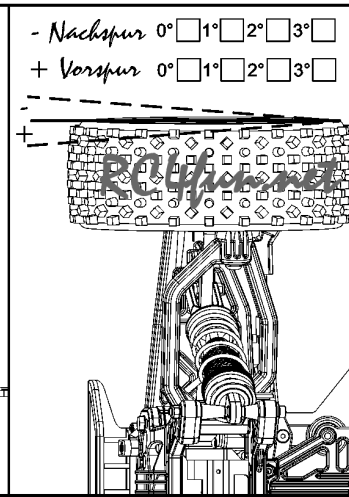
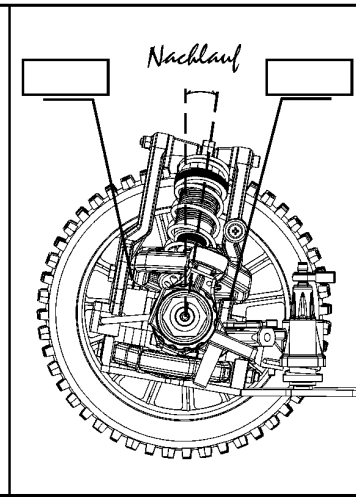
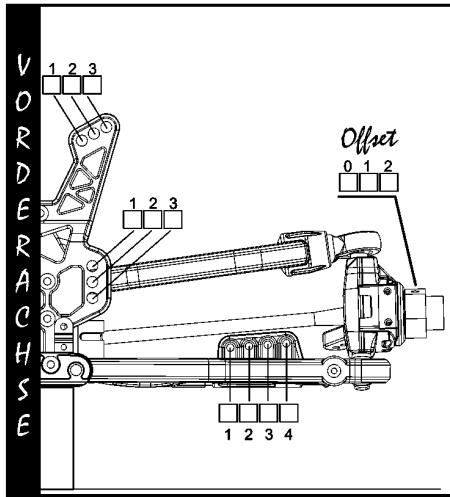

REIFEN

Vorne

Hinten

Mischung V H

Einlage V H

Ø 155mm 180mm

ANTRIEB

Motor

Verzaser

H L

Zündkerze

Öl Mischung 1:

Kupplung

Reso

Position Beste Rundenzeiten

NOTIZ

Race Runner